



2011 TRUCK RULES

"IF THE RULES DON'T SAY YOU CAN, THEN YOU CAN'T"

Weight

All specified weight requirements will be with driver, fuel, oil and water prior to racing.

1. Maximum allowable left side weight will be 56% of total weight with driver.
2. Minimum weight 2,800 pound with driver after race, one pound per lap will be deducted.
3. Additional weight may be added in block form of no less than 5-pound blocks (no pellets). Added weight must be securely bolted in place. Dislodged weight cannot be returned to car for weighing after race. All added weight must be painted white with truck number painted in red or black. Any lost weight will result in a \$10 per pound fine to the driver.

Interior

1. Truck interior must be complete and shield driver from ground, engine compartment and fuel cell area. Firewall must be no less than 24-gauge metal and fully seal driver from engine compartment.
2. Truck may have an installed dash panel with optional gauges. No digital gauges permitted.
3. ON-OFF switch must be located on dash within easy access of driver as well as access from outside left window opening. ON-Off positions must be clearly marked.
4. Quick release steering wheel is mandatory. Center top section steering post must be padded with at least 2" of padding material.
5. All roll bars surrounding driver must be padded. Padding must be acceptable to LNS Officials.
6. A window net must be installed in the left side door glass opening. The window net must be a rib type, made from nylon material with a minimum 1" square opening between the ribs. All window nets must have quick release mechanism and be welded to roll cage. The window net, when in the closed position, must fit tight when secured.
7. Rear view mirror permitted inside of truck only.

Body

The truck body must be acceptable to LNS Officials at all times. All body parts must have a minimum clearance of 4" prior to race with fuel, oil, and water, without driver. No truck will be allowed to start a race without a full body. Headlight and taillight decals recommend.

1. Bodies will be fiberglass, aluminum or PVC (rubber) replicas of the standard cab. No carbon fiber parts allowed. Note: Bed lids can be either fiberglass or sheet metal.
MUST BE AN OFFICIAL APPROVED MANUFACTURER ONLY
ARP Race Car Bodies, Five Star Race Car Bodies
1. Approved bodies: 2000-2010 Chevrolet C10/ C1500/ Silverado, 2000-2010 Ford F-150, 2000-2010 Dodge Ram, 2004-2010 Toyota.
2. Body must be mounted in the center of the frame and fit the 108-inch wheelbase of truck with wheels in center of wheel wells.
3. Minimum roof height must be 55 ½ ", measured from a point in the center of the roof 10" behind top of windshield. Maximum height at rear of roof is 56", maximum variance from a point 10" behind windshield to rear of roof is ½ ". Minimum rear deck height must be 36", measured where rear deck meets the spoiler. Minimum window opening must be at least 16".
4. Body must maintain original configuration, size and shape and must adhere to body template of LNS. A 3/4" tolerance will be allowed to template.
5. Screen wire grill mesh must cover all grill openings and be fastened to bodywork from inside of the grill.
6. Front and rear window opening must be covered with a minimum 1/8" inch thick clear polycarbonate. Clear polycarbonate must cover entire opening and should follow the contours of the body. Clear polycarbonate (1/8") side window vents are optional and cannot exceed 9" in height.
7. Front windshield opening should have a minimum of two 1" by 1/8" straps located in the center of the windshield behind the clear polycarbonate and placed no closer than 3" apart.
8. Hoods must remain flat. Positive fasteners must be installed with either a minimum of four hood pins or two hood pins and two rear hinges. A small notch, not to exceed 1.5", on the far passenger side of the hood will be allowed for an overheating tube.
9. Full rear deck lids are mandatory and must completely cover the rear of body. Deck lids can be either fiberglass or sheet metal. The rear half of the lid must be able to open for inspection purposes. Positive fasteners must be used on left and right side to secure opening position of the lid.
10. Front air dams must maintain original configuration and all body support brackets must be located inside the body structure.
11. Rear spoiler is mandatory. Maximum width of spoiler 60", measured across the backside of spoiler, maximum height of spoiler is 6". Spoilers must be solid 3/16" sheet metal or "clear polycarbonate. No forward

rudders or mounting brackets will be permitted. Minimum 4 mounting brackets or supports on the backside of spoiler. The maximum spoiler height is 44" from the ground, measured in the center of the spoiler.

Engine

Option #1

General Motors crate engine only, part number # 88958602. All GM sealing bolts must remain as installed from General Motors. Removal of sealing bolts will result in disqualification. *NOTE: see Carburetor and Ignition sections.*

Claimer rule on an engine is \$3500.00 after the race. Plus \$500.00, LNS retains \$400.00

Only drivers finishing the race, their crew chief or owner may claim a General Motors crate engine part number # 88958602 from a driver finishing the race ahead of the claiming driver. The claim will be limited to one truck and must be made within 10 minutes after completion of the feature event with the cash only claim fee to the Race Director or Chief Pit Steward. Not included in the claim are carburetor, water pump, distributor, ignition, pulleys, plug wires, fuel pump, flywheel, pressure plate and clutch. A claim fee will not be accepted should LNS Officials determine the claim fee has been made on someone else's behalf or the fee is from more than one party. Failure to pull and sell a claimed engine will result in the driver being claimed forfeiting all purse and points for the event

Option # 2

Ford Crate Engine, Part # M6007-S347JR. All engine parts must remain the same as they come from factory.

Option # 3

Engines Displacement: Chevrolet - 305 CID, maximum overbore .067, Ford - 302 CID maximum overbore .067, Dodge - 318 CID maximum overbore .067

1. Engines must be factory production OEM cast iron cylinder blocks built for standard production only (no aluminum blocks). Casting numbers must be unaltered and legible. Blocks may not be painted or coated in the interior. Block decks may be strengthened and blocks may be deburred. Blocks may not be offset bored and must maintain OEM type bearings in the main journals.
2. Only OEM steel or cast crankshafts permitted. No aftermarket steel, lightened, knife edged or otherwise racing crankshafts permitted. OEM stroke must be maintained.
3. OEM or OEM appearing after market rods permitted. Rods may not be polished or otherwise altered. Piston pins may be fitted or floated. No aluminum rods prohibited. Rod length: GM 5.70 inch, Ford 5.16 inch, Dodge 6.12 inch. I-Beam only.

4. Flat top or dished pistons permitted Wrist pin must remain in OEM position. Cast or forged pistons permitted. No coating, painting or otherwise alteration of pistons permitted. Minimum deck clearance is .000".

5. Compression ratio of engine is limited to 10:5 to 1.

Camshaft

Any manufacturer permitted. Maximum lift: Chevrolet .458", Ford .488, Dodge - .458".

Lifters

Only OEM or OEM replacement lifters permitted. No solid lifters or altered lifters to perform as solid lifters permitted. No oversize lifters permitted. Anti-pump lifters are allowed.

Rocker Arms

1. OEM rocker arms only permitted with OEM ratio: Chevrolet & Dodge 1.5, Ford
2. General Motors crate engine part number # 88958602 must run GM 1.5 ratio rocker arms, roller rocker arm not permitted.

3. Roller rocker arms permitted. No shaft type rocker arms permitted.

Cylinder Heads

1. Chevrolet must be GM stock cast iron 305 cylinder head, Dodge must be stock cast iron 318 head,-Ford must be stock cast iron 302 head. No aluminum or Vortec heads permitted except L-30 type heads. Must retain original 2 valves per cylinder.

2. Valve size; Chevrolet - intake maximum 1.84", exhaust maximum 1.5", Dodge - intake maximum 1.78", exhaust maximum 1.469", Ford - intake maximum 1.781", exhaust maximum 1.469". Ford & Dodge may use same size valves as Chevrolet.

3. No special after market valve permitted and valves may not be canted in heads.

4. No polishing, porting, matching of ports, acid washed or flowed allowed in any manner.

5. Studs may be pinned. Screw in studs permitted.

Valve Springs

Valve springs must retain stock diameter & height. Spring seats may not be enlarged or otherwise altered. Maximum spring seat pressure limited as follows: Chevrolet 115 lbs, Ford 115 lbs, Dodge 130 lbs.

Intake Manifolds

1. Only the following intake manifolds permitted with no substitutions allowed: Chevrolet Edelbrock #7101 or 7116, Ford Edelbrock #7121, Dodge Edelbrock #7176
2. No altering, polishing, porting or matching of ports allowed in any manor. No laser treating or micro holes allowed. Plenum may not be altered and no devices are permitted inside runners or plenum.

Starter

1. Must start under own power.OEM type starters permitted.

Carburetor

1. General Motors crate engine 602 - Holley 650 4150 Model #4777 four-barrel. No alterations, Subject to claim.
 - 1a.Built Motor Holley 500 CFM model number 4412 permitted No alterations, Subject to claim.
 - 1b.Claimer Rule on carburetor is \$375.00 after the race. If the claim is refused a two week suspension will be enforced. No points or purse.
2. Body of carburetor - no polishing, grinding or drilling of holes permitted. No paint or any other types of coating other than from carburetor manufacture are allowed inside or outside of carburetor.
3. Choke and choke horn may be removed, but all screws must be permanently sealed.
4. Booster size or shape must not be altered. Height must remain standard.
5. Venturi area must not be altered in any manor. Casting ring must not be removed.
6. Base plate must not be altered in shape or size.
7. Stock butterflies must be used and cannot be thinned or tapered. One idle hole may be drilled per butterfly. Screw ends may be cut even with shaft; screw heads must remain unaltered.
8. Throttle shafts must remain standard and cannot be thinned or cut in any manner. No silicone or epoxy allowed on throttle shafts.
9. Any attempt to pull outside air other than down through venturis is not permitted.
10. Throttle linkage must have at least 2 return springs. Throttle stop recommended.

Carburetor Spacer

1. Only one non adjustable one-piece solid aluminum spacer permitted maximum 1" in height, with 1 gasket per side not to exceed .065" in thickness. Spacer must have openings cut perpendicular, matching carburetor base, and no larger than base of carburetor opening. No taper or beveling permitted. No Open Spacers.

Ignition

1. Alternators permitted.
2. One battery permitted, maximum 12 volt and securely mounted. If mounted inside of drivers' compartment, battery must be covered.
3. Only one (1) MSD box per truck.

Crate engines must run MSD soft touch with maximum 6,000 RPM chip

Air Intake

1. Air cleaner cannot be removed at any time during competition or practice.
2. Only round dry type paper element 14"-16" in diameter, maximum 4" in height may be used in air cleaner at all times. Element may not be sprayed or soaked with any type of chemicals or liquids. All air shall be filtered through element. Air cleaner housing must be of metal type. Top of air cleaner must be solid, no holes. It will be permitted to shield the front area of the air cleaner up to a maximum of one half the air cleaners' diameter and not wider than the height of the air cleaner filter. Top and bottom of the air cleaner housing must be the same diameter. A maximum of a 1" lip from the air cleaner to the top and bottom edges of the air cleaner housing is permitted. Nothing may direct or control the flow of air inside or outside of the air cleaner housing except the air cleaner element.
3. Cowl induction, air ducts or baffles will not be permitted on or leading to the air cleaner. An opening 2 1/2" by 20" may be cut in the hood behind the carburetor with the back edge either meeting or a maximum of 1" from the windshield. A fresh air deflector will be permitted and must be placed at the center of the leading edge of the windshield directly under the hood opening. The fresh air deflector must be made of aluminum and measure a maximum of 2" down and 2" forward by 20" in width with square bends and no radius or air flow devices, end caps permitted no larger than 2" by 2".
4. No sheet metal heat shields or any other type of hot air deflection device or air flow deflection device will be allowed past the backside of the radiator or in the engine compartment.

Electrical

1. Alternator permitted.
2. Only one standard 12v battery permitted. Battery must be securely mounted outside and behind drivers' compartment.
3. Self-starter must be installed and operative. All race trucks must start under their own power.

Exhaust

1. Any type tubular header permitted must have single flange. Exhaust system must not exceed 4.0 inches in diameter, only collector may be larger. Exhaust system must exit behind driver and out right side.
2. True visible mufflers required and exhaust system sound must not exceed 100 decibels at 100 feet. No vortex cones.

Fuel System/Cell

1. Maximum 22-gallon fuel cell must be mounted in steel container with a minimum of two protective bars made of 1" square tubing, protection braces wrapping around fuel cell from front, underneath and to back of cell and a rear protection bar of 1.75" tubing extending below the rear of frame and at least 1/2" below the bottom of fuel cell to cover the width of the fuel cell. Fuel cell and steel container must be mounted in center of frame and behind centerline of rear axle. Fuel cell and container must have a minimum of 9 inches clearance from the ground. No pressurized cells permitted.
2. Only one fuel line permitted to transport fuel from cell to pump. Left or right side fuel pickup permitted. Fuel line must not run inside driver's compartment. No additional fuel cells or containers permitted. Electric fuel pumps prohibited. Only stock side block mounting mechanical pump permitted. After market fuel pumps are permitted but must be of same size and mount in stock location.
3. No icing, Freon type chemicals or refrigerants may be used in or near the fuel system or engine compartment. No cooling of fuel cell or fuel system.
4. **FUEL BURNED AT LNS MUST BE BOUGHT AT LNS.**

SAFETY EQUIPMENT

- a) All cars must have at least 3" safety belt and 2" shoulder harness.
- b) Window net mandatory.
- c) Driving suit made of some type of nomex material mandatory.
- d) Safety helmet mandatory.
- e) Fire extinguisher in car mandatory.

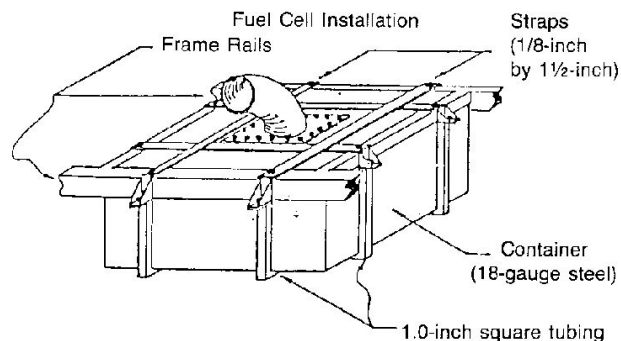

Container (18-gauge steel) for fuel cell must mount to frame rails via two (2) lateral and longitudinal braces forming grid beneath and on sides of cell container. Additionally, a two (2) lateral and longitudinal brace grid must cross the top of the cell container. It is strongly recommended grid members be fabricated from one-inch square tubing and 1 1/2-inch by 1/8-inch thick steel strapping is the minimum accepted material.

FUEL CELL

- a) Minimum ground clearance 9".

Cooling System

1. Only block mounted belt driven water pumps allowed. Water pump impellers may be altered. Fan type optional. Fan shroud may not extend more than 2" past fan blades. Electric fans permitted. Aluminum radiator permitted and must be mounted in front of engine.
2. Water only must be used in the cooling system. Any additive to water, Ex. Water Wetter, must be first approved by an LNS official. Any driver found using unapproved coolants must pay a \$100 fine before driver can compete at LNS. **No Anti Freeze**

Oiling System

1. Oiling system must be wet sump oiling system. Steel racing oil pans permitted. NO ALUMINUM. Oil pan baffles permitted and recommended. Only standard screw on OEM type oil filters permitted. Remote oil filters allowed.
2. Minimum ground clearance from bottom of pan is 4 inches.

Transmission

1. Only standard GM turbo 350, Ford C4 or C6, and Dodge 904 or 727 automatic transmissions allowed. Must have three forward gears and reverse. All gears must be working. Manual shift kits permitted. Reverse shift patterns permitted.
2. OEM type torque converters may be used. NO hollow converters allowed. Minimum ten-inch torque converters permitted.
3. No exterior valve mechanism or band adjusters allowed.
4. Transmission coolers permitted. All cooling lines must be steel braided with screw in fittings. No rubber hoses or clamps allowed.

Drive Shaft

Drive shafts and universals must be of similar design standard production type and must be made of steel. Minimum 3" diameter. Minimum one 360° loop of 1 inch by 1/8 steel secured to cross member or chassis, must be present to prevent drive shaft from dislodging from race vehicle. Drive shaft must be painted white with truck number painted in red or black.

Frame

GM metric frame only may be used. 1978-87 Chevrolet Malibu, Monte Carlo, Pontiac Grand Prix, Oldsmobile Cutlass, or Buick Regal. Frames must retain original 108-inch wheelbase. Maximum allowable difference from side to side is 1 inch. Frame may be fabricated from 6" off the centerline or rear axle to rear of

truck and from front sway bar forward. Holes may not be cut to lighten frame. Frame may be X'd. Frames may not be narrowed. Front cross member must remain original and, may not be notched, narrowed, cut or otherwise altered. Minimum ground clearance, prior to race with fuel, oil and water, without driver, is 4".

Roll Cage

1. LNS Officials must approve roll cage designs. Round steel tubing 1 ¾ " OD round tubing by .090" minimum wall thickness must be used to construct roll cage. Roll cage should be box type with a cross support in the back and a minimum 9" upright support at the left front support.
2. Left door must have a minimum of three bars in (four recommended) and must have 1/16" minimum steel plate from frame to top door bar.

Engine Placement

1. Engine must be centered between frame rails. Engine must be installed in its original position. No setbacks permitted. Engine must bolt securely and positively to mounts. No torque plates permitted.
2. Steel motor mounts permitted.

Wheels

Racing steel 15" wheels only, maximum rim width 8", maximum offset difference of 2". Air bleeders not permitted. Hubs must have 5/8" wheel studs. All wheels must have truck number on wheels.

Tires

1. Hoosier 27"X8", F53. Tires must have LNS purchase stamp and be purchased at track through LNS vendor. Tires must go directly to the impound area after mounting and once released must remain in sight at all times. Tires for use in the next event must be returned to the impound area immediately after racing. Drivers soaking or altering tires will forfeit all purse and points for the event and all track points for the year. Driver must also pay a \$1,000 fine prior to being allowed to compete at LNS. Any illegal tire, in the judgment of LNS Officials, will be confiscated.
2. The feature event must be started on the same set of tires (all four) that the truck used in qualifying or heat races. For 100 lap events only, drivers running in a last chance race may change tires before running the feature event. Damaged tires may be changed upon LNS Officials approval only.
3. Front and rear tread width is 63" maximum. Spacers are permitted to maintain tread width. Tread width is measured with referee.

Suspension

1. Front suspension components must remain stock for original frame used. Shock may be moved but, springs must mount in stock location.
2. After market tubular upper A-Arms with OEM ball joints and bolting directly to OEM spindles may be used. **Front sway bar must be one-piece sway bar** with a maximum diameter of 1.250". No heim joints on sway bars permitted. Coil springs may be replaced but must mount in OEM stock locations on lower A-Frame and rear axle.
3. **Only one shock permitted per wheel. All shocks must be steel, non-adjustable. No coil over shocks or coil over converted shocks permitted, no air, or remote reservoir shocks. No Schrader valves No bumpers or stops, No threaded body or cups.(Subject to claim. See forward section.)** Coil spring rubber inserts permitted. No leaf springs or torsion bars permitted. All bushings must be of stock dimensions. Rear sway bar permitted, but must be OEM stock bar. No Heim joints permitted. Must use stock type bushings.
4. Claimer rule on shocks is \$125.00 per shock.

Steering

Steering box may not be removed from factory location. Universal joints, up to 3 can be on steering shaft as well as Heim joints. No rack and pinion steering allowed. After market stock power steering kits or steering quickener kits allowed. Steering wheels up to 17" quick release spring locked metal is required. No nylon inserts permitted. Original OEM steering must be used. Pitman arm, center link and idler arm must be of original GM type used with this frame or stock after market replacement. Heim type tie rod permitted.

Rear End

1. Rear trailing arms must be stock and mounted in original brackets or original holes.. No Heim joints permitted. Rear trailing arms may be strengthened by welding one-inch strips on bottom with minimum of one inch between strips. No solid enclosed trailing arms permitted.
2. Rear end must be original 10 bolt GM. Gears must be original 7.5" diameter. Any ring and pinion ratio permitted. Welded spider gears, mini spools, positive traction units, and locker type rear ends permitted. 323 342 373 410 456 gear ratio

Brakes

Front brakes must use original OEM appearing calipers. If heavy-duty hubs or rotors are used, they must bolt directly to OEM spindle and use OEM caliper. No adapters are permitted. Rear brakes must use OEM or OEM replacement components and any hubs or heavy-duty replacement hubs must attach to OEM axle and backing plate. Rear disc brakes allowed. After market brake pedal assembly allowed, with double reservoir master cylinder required to be mounted on engine side of firewall. No aluminum brake rotors or drums allowed. Aluminum rotor hat permitted. Brakes must function on all four wheels.

Protest Fee

A- One Head & Flywheel.....	\$400.00
B- Two Heads.....	\$600.00
C- Oil Pan.....	\$200.00
D- Check fuel.....	\$100.00
E- Check wheel base and set back.....	\$100.00
F- Check carburetor.....	\$ 50.00
G- Check left side weight.....	\$ 50.00
H- Check complete car.....	\$800.00
I- Check Suspension.....	\$100.00